



www.DanaherMotion.com

*Installation Instructions for SLO-SYN[®]
MODEL SS2000MD4 Translator Drive*

400030-043 Rev G



Record of Manual Revisions

ISSUE	Date	Description of Revision
G	09/12/2003	Updated corporate information

Copyright Information

© Copyright 1992 - 2003 Danaher Motion - All rights reserved.
Printed in the United States of America.

NOTICE:

Not for use or disclosure outside of Danaher Motion except under written agreement. All rights are reserved. No part of this book shall be reproduced, stored in retrieval form, or transmitted by any means, electronic, mechanical, photocopying, recording, or otherwise without the written permission from the publisher. While every precaution has been taken in the preparation of the book, the publisher assumes no responsibility for errors or omissions. Neither is any liability assumed for damages resulting from the use of the information contained herein.

This document is proprietary information of Danaher Motion that is furnished for customer use ONLY. No other uses are authorized without written permission of Danaher Motion. Information in this document is subject to change without notice and does not represent a commitment on the part of Danaher Motion. Therefore, information contained in this manual may be updated from time-to-time due to product improvements, etc., and may not conform in every respect to former issues.

Safety

Safety symbols used in this manual are:



Warning Alerts users to potential physical danger or harm. Failure to follow warning notices could result in personal injury or death.



Caution Directs attention to general precautions, which if not followed, could result in personal injury and/or equipment damage.



Note Highlights information critical to your understanding or use of the product.

Instructions

Only qualified personnel should install or perform servicing procedures on this equipment. *Do not* operate the unit without the enclosures in place as voltage present in this unit can cause serious or fatal injury.

Before performing any work on the unit, allow at least five minutes for the capacitors to discharge fully.

Voltage is present on unprotected pins when unit is operational.

The "PWR ON" LED must be off for approximately 30 seconds before making or breaking the motor connections.

Motors powered by these drives may develop extremely high torque. Disconnect AC power to these drive before doing any mechanical work.



This unit is designed for 115 VAC input only (see Section 4.2, Electrical Specifications).

Warranty And Limitation Of Liability

Danaher Motion (the "Company") warrants to the first end user purchaser (the "purchaser") of equipment manufactured by the Company that such equipment, if new, unused and in original unopened cartons at the time of purchase, is free from defects in material and workmanship under normal use and service for a period of one year from date of shipment from the Company's factory or a warehouse of the Company in the event that the equipment is purchased from the Company or for a period of one year from the date of shipment from the business establishment of an authorized distributor of the Company in the event that the equipment is purchased from an authorized distributor.

THE COMPANY'S OBLIGATION UNDER THIS WARRANTY SHALL BE STRICTLY AND EXCLUSIVELY LIMITED TO REPAIRING OR REPLACING, AT THE FACTORY OR A SERVICE CENTER OF THE COMPANY, ANY SUCH EQUIPMENT OR PARTS THEREOF WHICH AN AUTHORIZED REPRESENTATIVE OF THE COMPANY FINDS TO BE DEFECTIVE IN MATERIAL OR WORKMANSHIP UNDER NORMAL USE AND SERVICE WITHIN SUCH PERIOD OF ONE YEAR. THE COMPANY RESERVES THE RIGHT TO SATISFY SUCH OBLIGATION IN FULL BY REFUNDING THE FULL PURCHASE PRICE OF ANY SUCH DEFECTIVE EQUIPMENT. This warranty does not apply to any equipment which has been tampered with or altered in any way, improperly installed or has been subject to misuse, neglect or accident.

THE FOREGOING WARRANTY IS IN LIEU OF ANY OTHER WARRANTIES, EXPRESS OR IMPLIED, INCLUDING, WITHOUT LIMITATION, ANY IMPLIED WARRANTY OF MERCHANTABILITY OR FITNESS FOR A PARTICULAR PURPOSE, and of any other obligations or liabilities on the part of the Company; and no person is authorized to assume for the Company any other liability with respect to equipment manufactured by the Company. The Company shall have no liability with respect to equipment not of its manufacture. **THE COMPANY SHALL HAVE NO LIABILITY WHATSOEVER IN ANY EVENT FOR PAYMENT OF ANY INCIDENTAL OR CONSEQUENTIAL DAMAGES, INCLUDING, WITHOUT LIMITATION, DAMAGES FOR INJURY TO ANY PERSON OR PROPERTY.**

Written authorization to return any equipment or parts thereof must be obtained from the Company. The Company shall not be responsible for any transportation charges.

IF FOR ANY REASON ANY OF THE FOREGOING PROVISIONS SHALL BE INEFFECTIVE, THE COMPANY'S LIABILITY FOR DAMAGES ARISING OUT OF ITS MANUFACTURE OR SALE OF EQUIPMENT, OR USE THEREOF, WHETHER SUCH LIABILITY IS BASED ON WARRANTY, CONTRACT, NEGLIGENCE, STRICT LIABILITY IN TORT OR OTHERWISE, SHALL NOT IN ANY EVENT EXCEED THE FULL PURCHASE PRICE OF SUCH EQUIPMENT.

Any action against the Company based upon any liability or obligation arising hereunder or under any law applicable to the sale of equipment, or the use thereof, must be commenced within one year after the cause of such action arises.

The right to make engineering refinements on all products is reserved. Dimensions and other details are subject to change.

Table of Contents

SECTION 1: INTRODUCTION	6
1.1 USING THIS MANUAL	6
1.2 PRODUCT FEATURES	6
SECTION 2: EXPRESS START UP	7
SECTION 3: INSTALLATION GUIDELINES	8
3.1 MOUNTING	8
3.2 TERMINAL LOCATIONS AND ASSIGNMENTS	9
3.3.1 MOTOR CONNECTIONS	10
3.3.2 POWER INPUT	12
SECTION 4: SPECIFICATIONS	13
4.1 MECHANICAL	13
4.2 ELECTRICAL	13
4.3 ENVIRONMENTAL	13
4.4 MOTOR COMPATIBILITY	13
4.5 CURRENT SETTINGS	15
4.6 STEP RESOLUTION	15
4.7 SIGNAL SPECIFICATIONS	16
4.7.1 CONNECTOR PIN ASSIGNMENTS	16
4.7.2 SIGNAL DESCRIPTIONS	16
4.7.3 LEVEL REQUIREMENTS	16
4.7.4 TIMING REQUIREMENTS	17
4.8 INDICATOR LIGHTS	17
SECTION 5: TORQUE VERSUS SPEED CHARACTERISTICS	18
5.1 MOTOR PERFORMANCE	18
5.2 TYPICAL TORQUE VERSUS SPEED CURVES	19
SECTION 6: SYSTEM CHECKING	35
APPENDIX A: TROUBLESHOOTING	36
A.1 ELECTRICAL INTERFERENCE PROBLEMS	36
A.2 CUSTOMER SUPPORT	36

SECTION 1: INTRODUCTION

1.1 USING THIS MANUAL

It is important that you understand how this SLO-SYN[®] 2000MD4 Translator/Drive is installed and operated before you attempt to use it. **Read this manual completely before proceeding with the installation of this unit.**

This manual is an installation and operating guide to the SLO-SYN 2000MD4 Translator/Drive. Section 1 gives an overview of the Drive and its features. Section 2 describes the steps necessary to place the drive into operation. General wiring guidelines as well as the physical mounting of the unit and connections to the drive portion are covered in Section 3.

Complete specifications, listed in Section 4, provide electrical, mechanical and performance specifications. The procedure for setting the motor current level is also covered in this section.

Torque versus speed characteristics with all appropriate SLO-SYN Stepper Motors are given in Section 5. Section 6, System Checking, gives procedures to follow if the SLO-SYN 2000 drive fails to operate properly.

Appendix A provides procedures for troubleshooting electrical interference problems.

1.2 PRODUCT FEATURES

SLO-SYN 2000MD4 Translator/Drive is a bipolar, adjustable speed, two-phase PWM drive that uses hybrid power devices. It can be set to operate a step motor in full steps or half steps. The maximum running speed is 3,000 rpm. To reduce the chances of electrical noise problems, the control signals are optically isolated from the drive circuit. Features include:

- Switch selectable current levels of 0.5 through 3.5 amperes
- Full short circuit protection (phase-to-phase and phase-to-ground)
- Undervoltage and transient overvoltage protection
- Efficient thermal design
- Optically isolated inputs
- Windings Off capability
- Switch selectable step resolution
- Compact size
- Sturdy all-aluminum mounting base

SECTION 2: EXPRESS START UP

The following instructions define the minimum steps necessary to make your **Drive** operational.



Always disconnect the AC power to the unit and be certain the "PWR ON" LED is OFF before connecting or disconnecting the motor leads. FAILURE TO DO THIS RESULTS IN A SHOCK HAZARD.

Always operate the Motor and the Drive GROUNDED. Be sure to twist together the wires for each motor phase. Six twists per foot is a good guideline.

1. Check to see that the motor used is compatible with the drive. Refer to Section 4.4 for a list of compatible motors.
2. Set the correct current level for the motor being used per the instructions in Section 4.5. **Heat sinking may be required to maintain case temperature below +70° C (+158° F).**
3. Select the appropriate step resolution and set the front panel switches as described in Section 4.6.
4. Wire the motor per the "Motor Connections" description in Section 3.2.
5. Connect the power source to the DC input terminal strip. Be sure to follow the instructions for connecting the filter capacitor as described in Section 3.2, under Power Input.



If the motor operates erratically, refer to Section 5, "Torque Versus Speed Characteristics". Clockwise and counter-clockwise directions are properly oriented when viewing the motor from the end opposite the mounting flange.

Section 3: Installation Guidelines

3.1 MOUNTING

The SLO-SYN Drive is mounted by fastening its mounting brackets to a flat surface as shown in Figure 3.1. If the drive assembly is mounted against a bulkhead, be sure to apply a thin coating of thermal compound between the drive and the mounting surface before fastening the unit in place. Do not use too much thermal compound. It is better to use too little than too much.

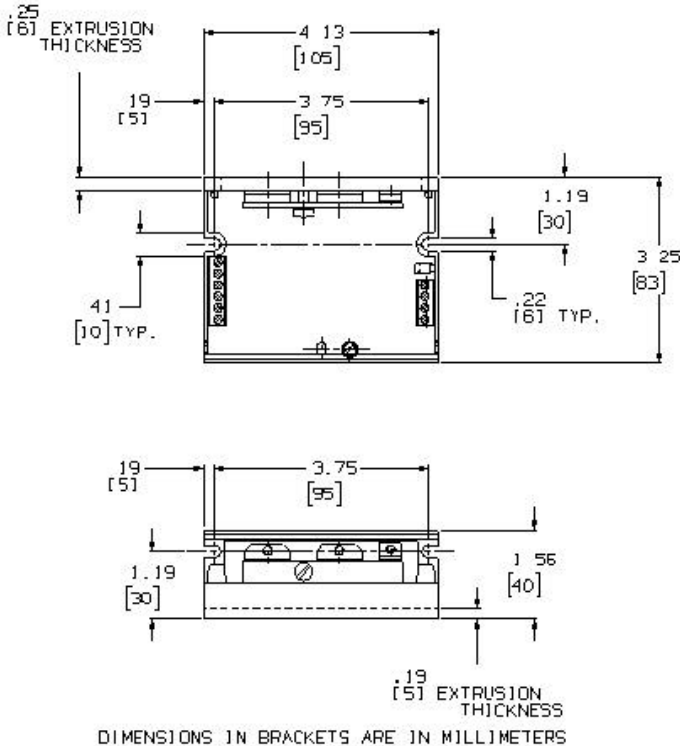

Figure 3.1 Mounting Diagram



Case temperature should not exceed +70° C (+158° F). Forced air cooling may be required to maintain temperature within the stated limits.

When selecting a mounting location, it is important to leave at least two inches (51mm) of space around the top, bottom and sides of the unit to allow proper airflow for cooling. It is also important to keep the drive away from obvious noise sources. If possible, locate the drive in its own metal enclosure to shield it and its wiring from electrical noise sources. If this cannot be done, keep the drive at least three feet from any noise sources.

3.2 TERMINAL LOCATIONS AND ASSIGNMENTS

Figure 3.2 shows the terminal locations for the SLO-SYN SS2000MD4 Translator/Drive.



I/O Connector (J2)

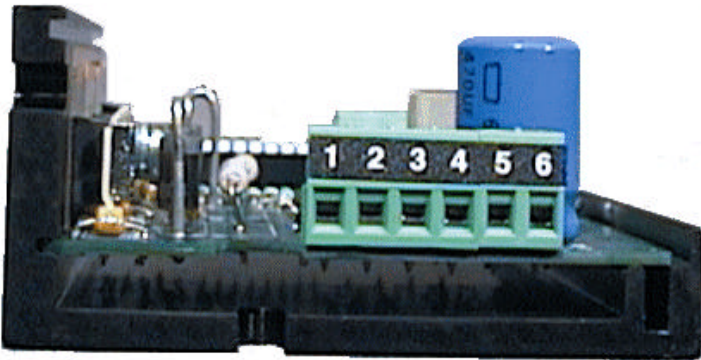

Motor And Power Supply Connector (J1)

Figure 3.2, Terminal Locations

3.3.1 Motor Connections

All motor connections are made via the 6-terminal strip (J1). Terminal assignments are given below. Motor connections are shown in Figure 3.3.

J1 Pin	Assignment
1	M1 (Phase A+)
2	M3 (Phase A-)
3	M4 (Phase B+)
4	M5 (Phase B-)



Motor phase A is M1 and M3 and motor phase B is M4 and M5. The motor frame must be grounded.

Cabling from the drive to the motor should be done with a shielded, twisted pair cable. As a guideline, the wires for each motor phase should be twisted about six times per foot.

Danaher Motion offers the following motor cable configurations. These cables have unterminated leads on both ends.

Length	Part Number
10 ft (3 m)	216022-031
25 ft (7.6 m)	216022-032
50 ft (15.2 m)	216022-033
75 ft (22.8 m)	216022-034

Figure 3.3 shows the possible motor wiring configurations.

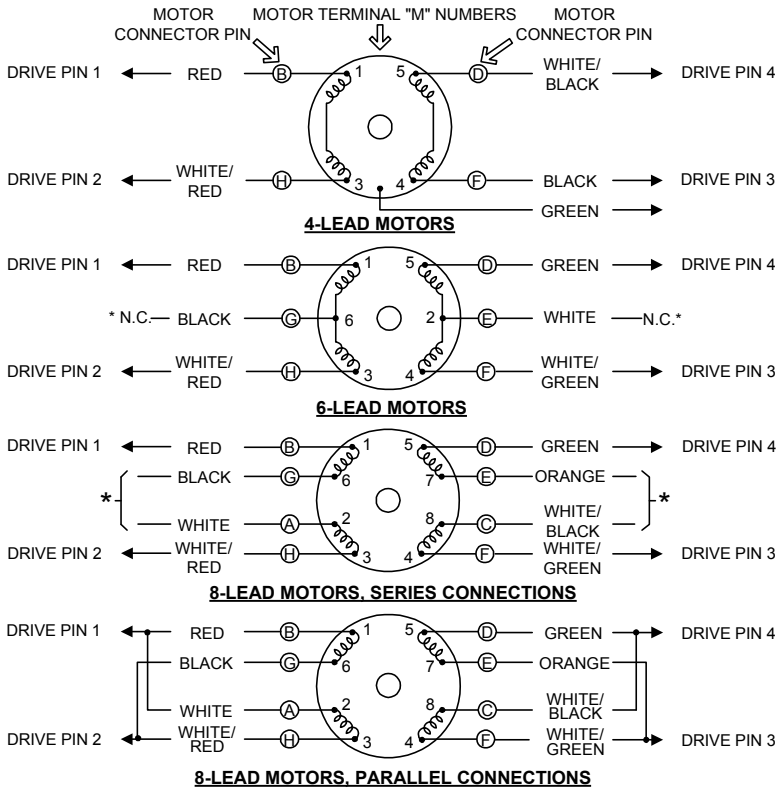

***These leads must be insulated and isolated from other leads or ground.**
 Circled letters identify terminals for connector motors, numbers identify those for terminal box motors.
Figure 3.3 Motor Wiring Configurations

3.3.2 Power Input

The DC input power is connected to terminals 5 and 6 of the terminal strip (J1). Terminal 5 [Vm(+)] is the power supply plus (+) connection and pin 6 [Vom(-)] is the power supply minus (-) connection.

An unregulated supply similar to that shown in Figure 3.4 is preferable. If a regulated supply is used, it must be capable of operating with the added filter capacitor. A switching regulated supply may not be suitable for use with this drive. It is important that the capacitor (C1) be connected within three feet (0.9 meter) of the input terminals. The capacitor must be of the correct value and have the proper current and voltage parameters (see list of components).

It is recommended that the power supply leads be twisted together (6 twists per foot).



If the power supply is grounded, it must only be grounded on the negative side or the short circuit protection will not operate properly.

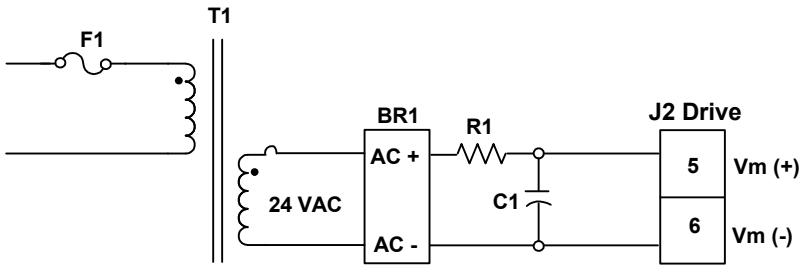

The cable between the filter capacitor (C1) and the drive should be twisted (six twists per foot). Maximum wire length is three feet.

Use #16 AWG or larger wire.

Figure 3.4 Typical Power Supply For A Single Drive Application

Components	
F1	1.5 ampere time delay, 250 volt
R1	5 ohm surge limiter, Phillips 2322-654-6158 or equivalent
T1	130 VA, 24 VAC output
BR1	General Instrument GBPC3502 or equivalent
C1	4700 μ f, 5.5 ampere 20 kHz, 63 V rated, United Chemcon 53D472F063HS6 or equivalent

SECTION 4: SPECIFICATIONS

4.1 MECHANICAL

Size

(Inches) 1.56 H x 4.13 W x 3.25 D

(mm) 40 H x 105 W x 83 D

Weight 0.6 pounds (272 grams)

4.2 ELECTRICAL

DC Input Range..... 24 VDC min., 40 VDC max.

DC Current see Motor Table

Drive Power Dissipation

(Worse Case)..... 35 watts

4.3 ENVIRONMENTAL

Temperature

Operating

+32° F to +122° F

(0° C to +50° C) free air ambient, Natural Convection. Maximum heat sink temperature of 158° F (70° C) must be maintained.

Forced-air cooling may be required.

Storage

-40° F to +167° F

(-40° C to +75° C)

Humidity

95% max. non-condensing

Altitude

10,000 feet (3048 m) max.

4.4 MOTOR COMPATIBILITY

Motor Types Superior Electric KM and M Series

M Frame Sizes M061 (NEMA 23D) through M092 (NEMA 34)

KM Frame Sizes KML061 (NEMA 23) through KML093 (NEMA 34)

M061 — M092

D6: KML060 — KML093

M061 — MH112



Do Not use larger frame size motor than those listed, or the drive may be damaged.

Number of

Connections

4, 6, 8

Minimum Inductance

0.5 millihenrys

Maximum Resistance

0.25 x VDC Supply/I Setting



Maximum resistance is total of motor plus cable.

Example:

VDC = 30 I Setting = 3.5

R max. = 0.25 x 30/3.5 = 2.1 ohms

MOTORS FOR USE WITH THE SS2000MD4 TRANSLATOR/DRIVE

Motor	Winding	Connection	Current Setting (Amperes)	Power Supply Current	
				Standstill (Amps. DC)	Maximum (Amps. DC)
M061	08	Series	2.5	1.0	2.0
M061	08	Parallel	3.5	1.0	2.0
M062	09	Series	3.0	1.0	2.5
M062	09	Parallel	3.5	1.0	3.5
M063	09	Series	3.0	1.5	2.0
M063	09	Parallel	3.5	1.0	3.5
M091	09	Series	3.0	1.0	1.5
M091	09	Parallel	3.5	1.0	3.0
M092	09	Series	3.0	1.5	2.0
M092	09	Parallel	3.5	1.0	3.0
KML060FO5	-	-	2.5	1.0	1.5
KML061FO5	-	-	2.5	1.2	1.5
KML061F11	-	-	3.5	1.0	3.0
KML062F07	-	-	3.0	1.0	2.5
KML062F13	-	-	3.5	1.0	4.0
KML063F07	-	-	3.0	1.5	2.0
KML063F13	-	-	3.5	1.0	4.0
KML091F07	-	-	3.0	1.0	2.0
KML091F13	-	-	3.5	1.0	4.0
KML092F07	-	-	3.0	1.5	2.5
KML092F13	-	-	3.5	1.0	4.0
KML093F07	-	-	3.5	1.8	2.5

Power supply currents shown are measured at the output of the rectifier bridge in Figure 3.4.

M061, M062 and M063 motors listed include LS, LE, CS, FC and FD versions. M091 and M092 motors include FC and FD versions with 6 or 8 leads. Motors with windings other than those listed can be used as long as the current ratings listed on the motors are not exceeded.

All KML motors listed have 4 leads.

4.5 CURRENT SETTINGS

The proper current setting for each motor is shown on the individual torque vs. speed curves. Use this current level to obtain the torque shown. Switches 1 through 7 select the current level. Select the desired operating current by setting the appropriate switch to position 1 (ON). The OFF position is labeled "0". Only one switch should be ON. If two or more switches are ON, the one that selects the highest current level is the active switch. The switch settings are:

Position	Current (amperes)
None	0.5
1	0.75
2	1.0
3	1.5
4	2.0
5	2.5
6	3.0
7	3.5

4.6 STEP RESOLUTION

The number of pulses per revolution is selected using position 8 of the switch described in Section 4.5. The following chart shows the correct switch setting for each available step resolution.

Switch Position 8	Step Resolution	Pulses Per Revolution
0 (off)	Full-Step	200
1 (on)	Half-Step	400

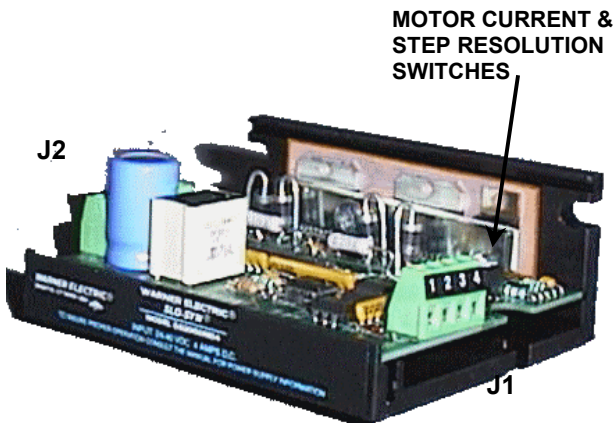

Figure 4.1 Switches For Setting Current Level and Step Resolution

4.7 SIGNAL SPECIFICATIONS

4.7.1 Connector Pin Assignments

All connections are made via the 4-pin terminal strip (J2).

Pin	Assignment
1	OPTO
2	PULSE
3	DIR
4	AWO

4.7.2 Signal Descriptions

OPTO Opto-Isolator Supply
User supplied power for the opto-isolators.

PULSE Pulse Input
A low to high transition on this pin advances the motor one step. The step size is determined by the Step Resolution switch setting.

DIR Direction Input
When this signal is high, motor rotation is clockwise. Motor rotation is counter-clockwise when this signal is low.

Clockwise and counter-clockwise directions are properly oriented when viewing the motor from the end opposite the mounting flange.

AWO All Windings Off Input
When this signal is low, AC and DC current to the motor will be zero. **There is no holding torque when the AWO signal is low.**



If you are using the drive with an MX2000, SS2000I or SS2000I-V control, the READY input and the OPTO input on the control must be jumpered together.

4.7.3 Level Requirements

OPTO
Voltage 4.5 to 6.0 VDC
Current..... 16 mA per signal used

Other Signals
Voltage
Low ≤ 0.8 VDC
 ≥ 0.0 VDC
High \leq OPTO
 \geq OPTO - 1 volt
Current
Low ≤ 16 mA
High ≤ 0.2 mA

4.7.4 Timing Requirements

PULSE

- Max. Frequency 20 kHz
- Max. Rise and Fall Times 1 microsecond
- Min. Pulse Width 25 microseconds

Other Signals

- Response Time ≤ 25 microseconds

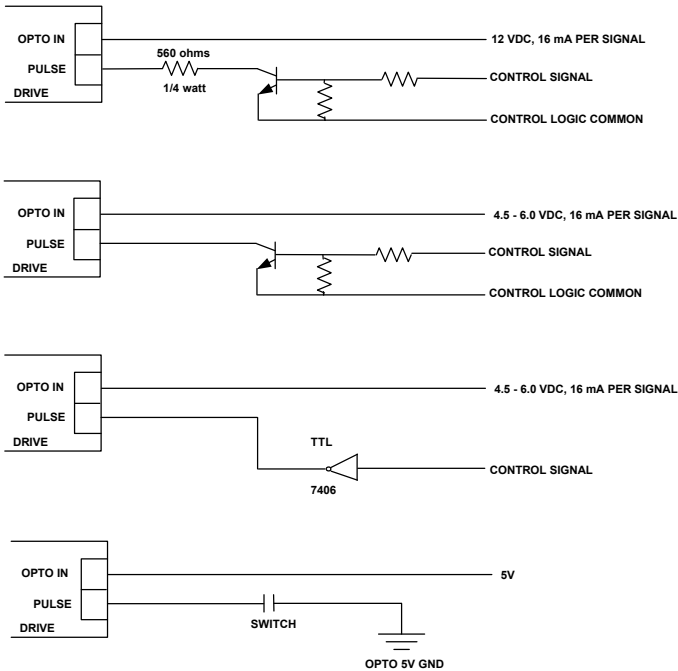

Figure 4.2 Suggested Methods For Control Interface

4.8 INDICATOR LIGHTS

"FAULT" LED, Red

Lights to indicate over current condition. This condition is caused by motor wiring errors or a ground fault.

Recovery from over current condition requires removing and then reapplying the power.

SECTION 5: TORQUE VERSUS SPEED CHARACTERISTICS

5.1 MOTOR PERFORMANCE

All stepper motors exhibit instability at their natural frequency and harmonics of that frequency. Typically, this instability occurs at speeds between 50 and 1000 full steps per second and, depending on the dynamic motor load parameters, cause excessive velocity modulation or improper positioning. This type of instability is represented by the open area at the low end of each Torque vs. Speed curve.

There are also other instabilities that cause a loss of torque at stepping rates outside the range of natural resonance frequencies. One such instability is broadly defined as mid-range instability. Usually, the damping of the system and acceleration/deceleration through the resonance areas aid in reducing instability to a level that provides smooth shaft velocity and accurate positioning. If instability does cause unacceptable performance under actual operating conditions, use the following techniques to reduce velocity modulation.

- 1) Avoid constant speed operation at the motors unstable frequencies. Select a base speed above the motors resonant frequencies and adjust acceleration and deceleration to move the motor through unstable regions quickly.
- 2) The motor winding current can be reduced as discussed in Section 4.5. Lowering the current reduces torque proportionally. The reduced energy delivered to the motor can decrease velocity modulation.
- 3) Use the half-step mode of operation or use microstepping to provide smoother operation and reduce the effects of mid range instability. **Microstepping reduces the shaft speed for a given pulse input rate.**

5.2 TYPICAL TORQUE VERSUS SPEED CURVES

The test conditions used when obtaining the torque versus speed data are listed in the lower left-hand corner of each curve.

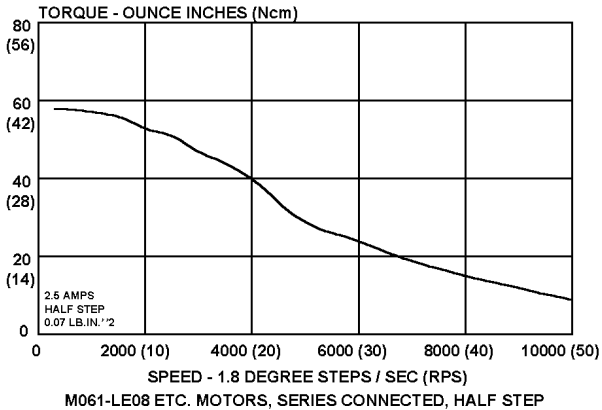
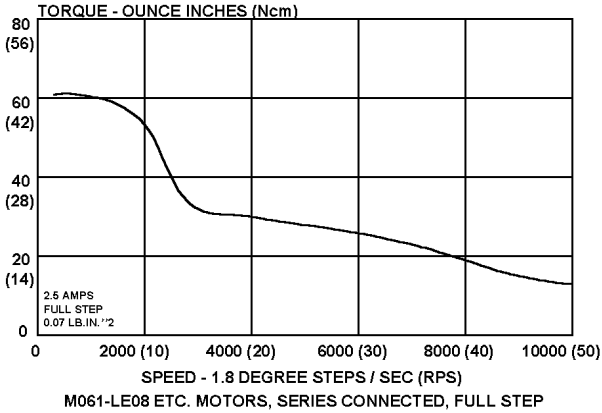

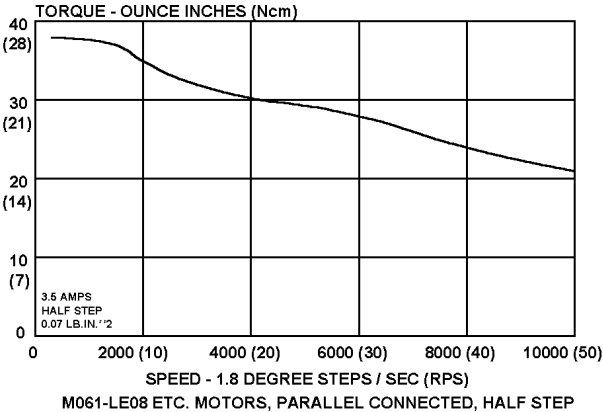
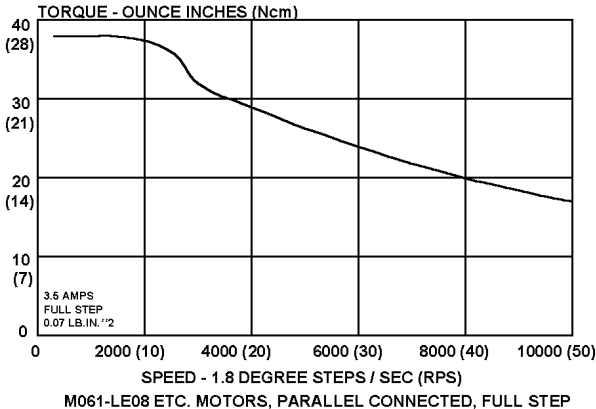

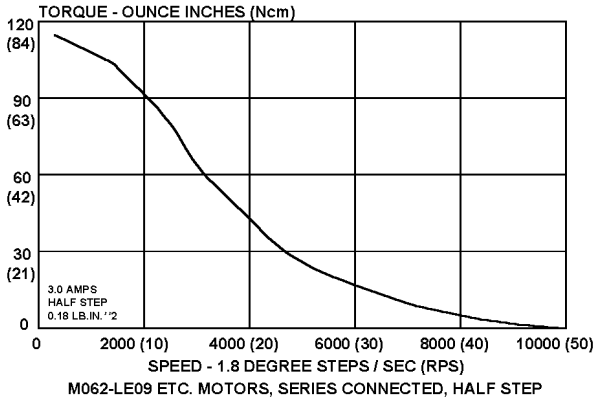
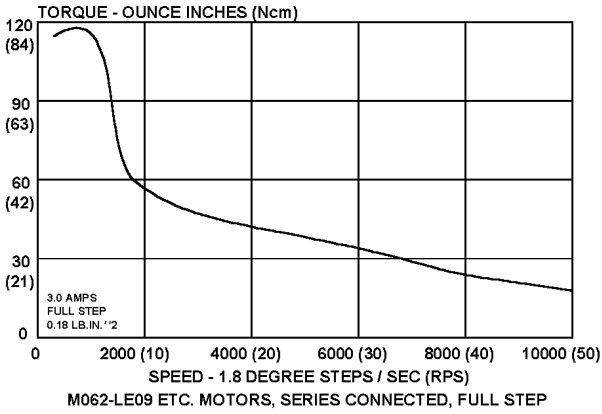

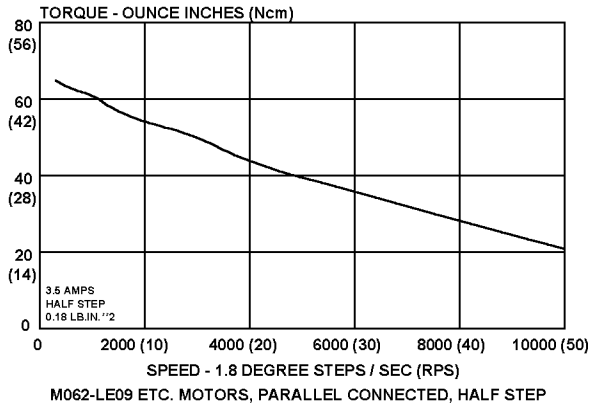
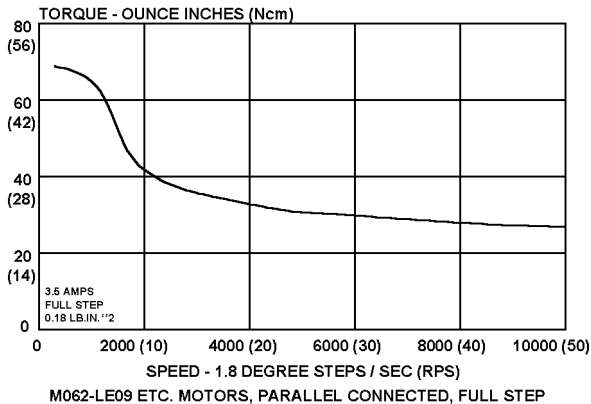

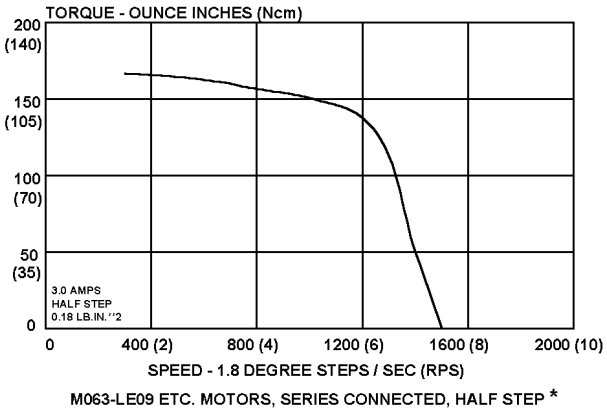
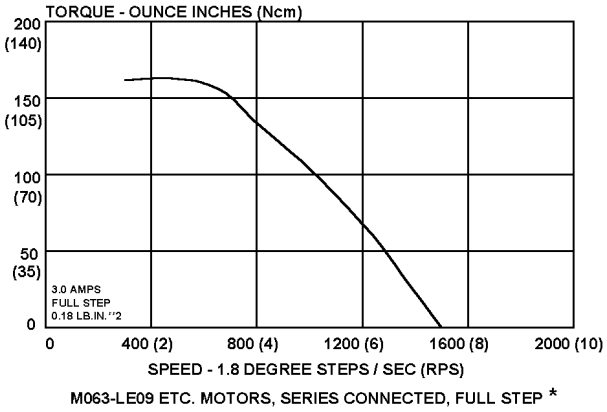

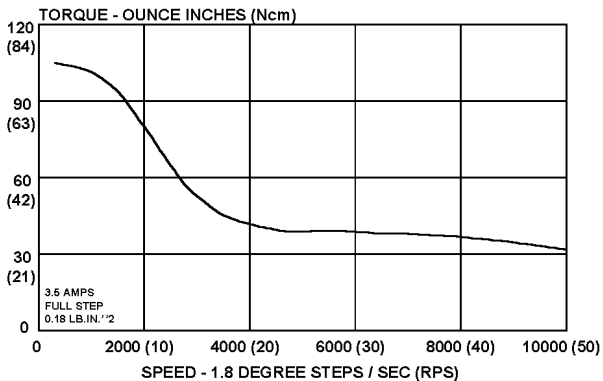

M063-LE09 ETC. MOTORS, PARALLEL CONNECTED, FULL STEP *

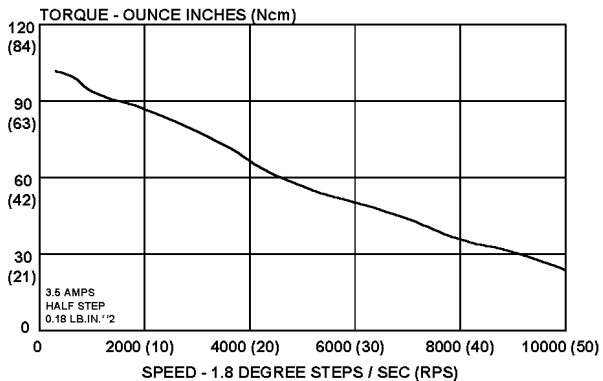

M063-LE09 ETC. MOTORS, PARALLEL CONNECTED, HALF STEP *

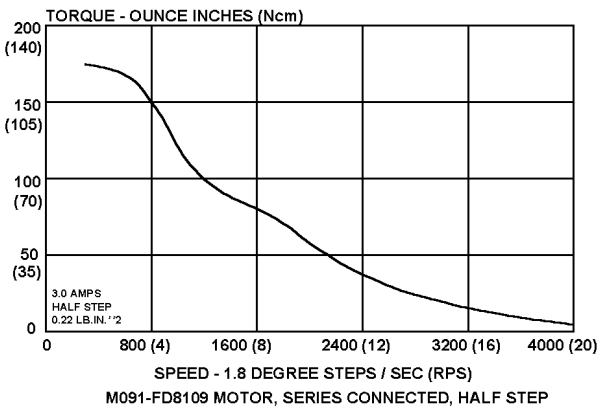
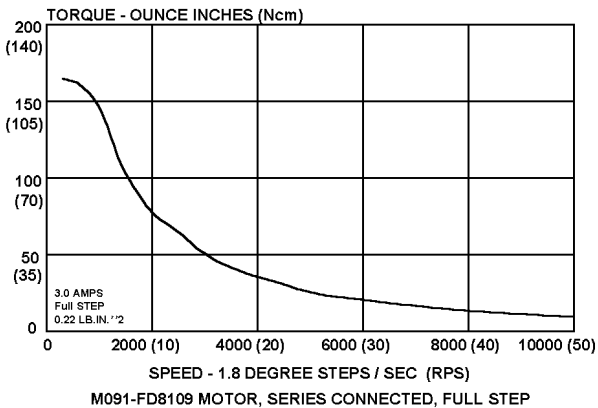

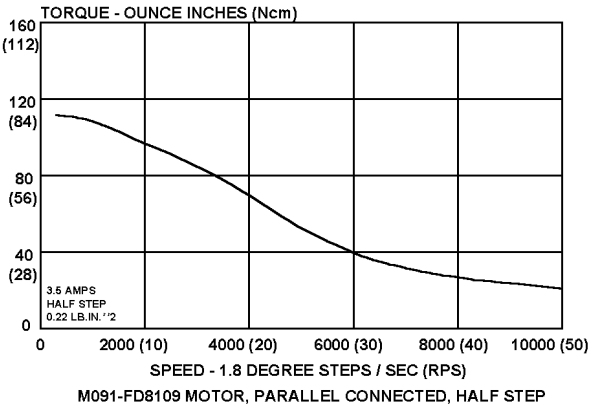
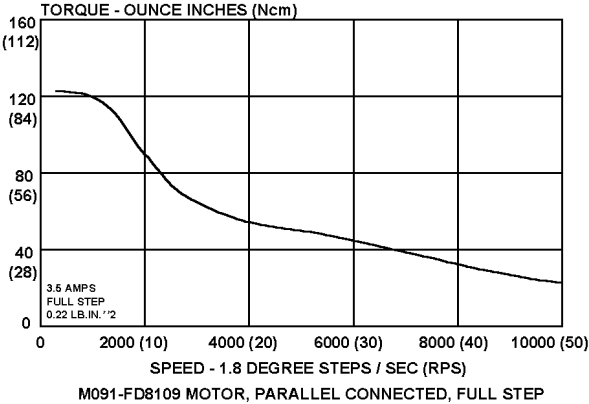

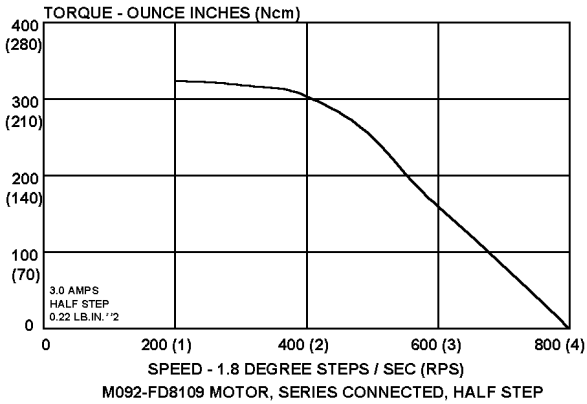
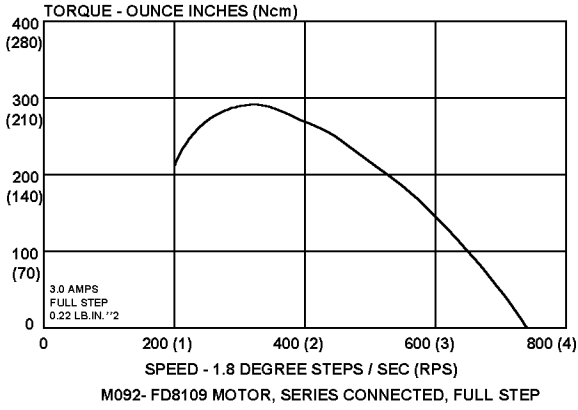

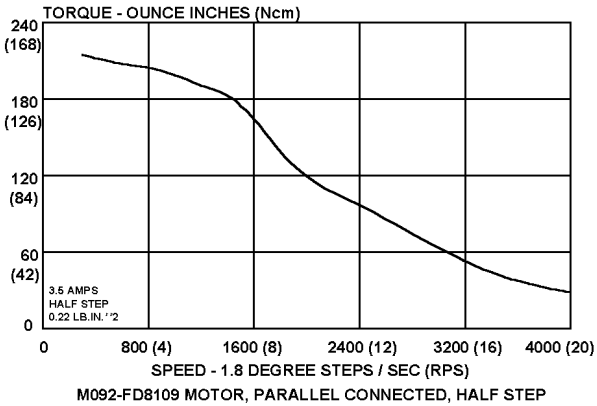
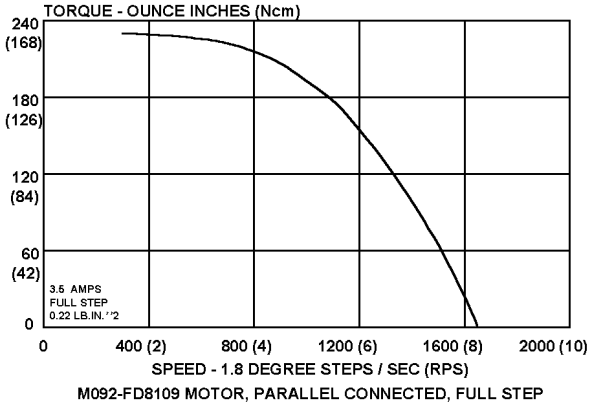

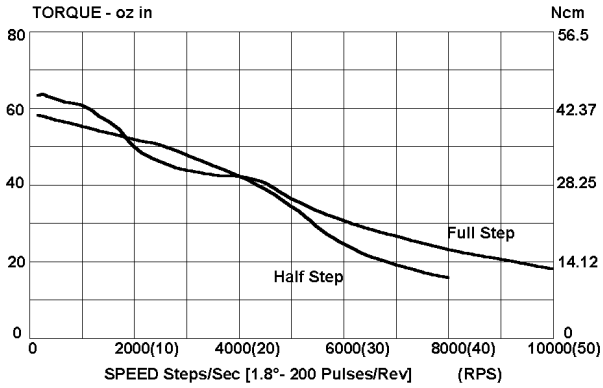

KML060F05, 2.5 Amp

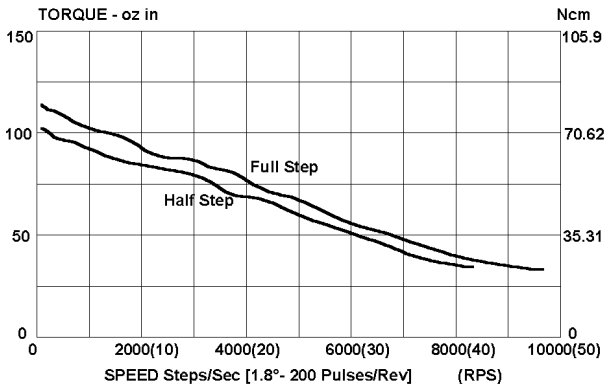

KML061F11, 3.5 Amp

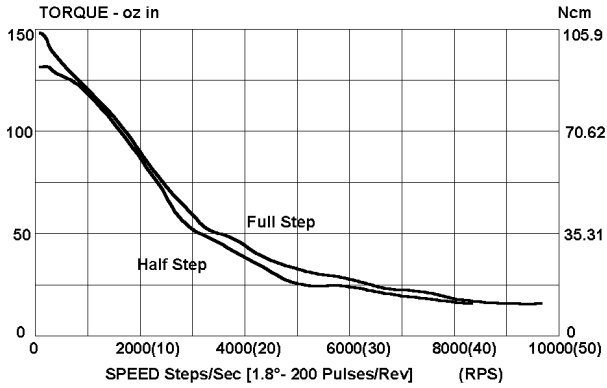

KML061F05, 2.5 Amp

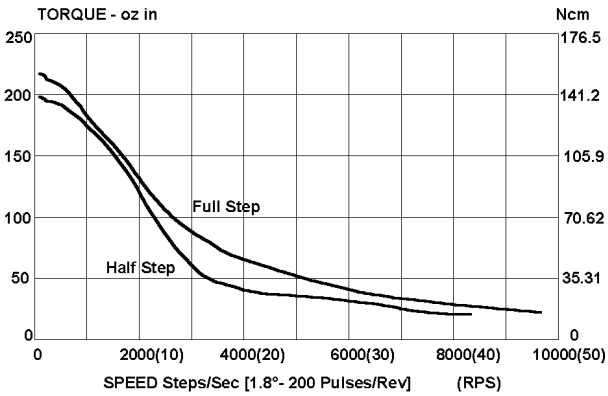

KML062F07, 3.0 Amp

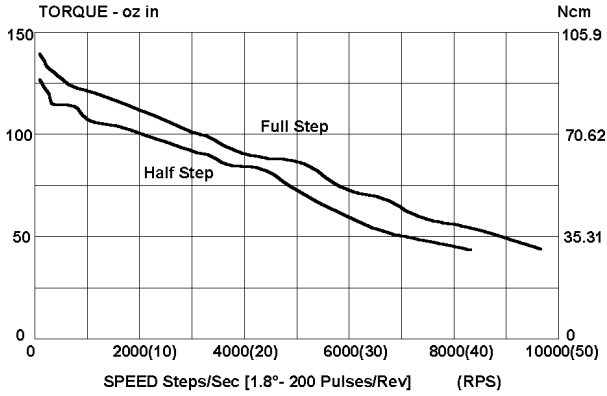

KML062F13, 3.5 Amp

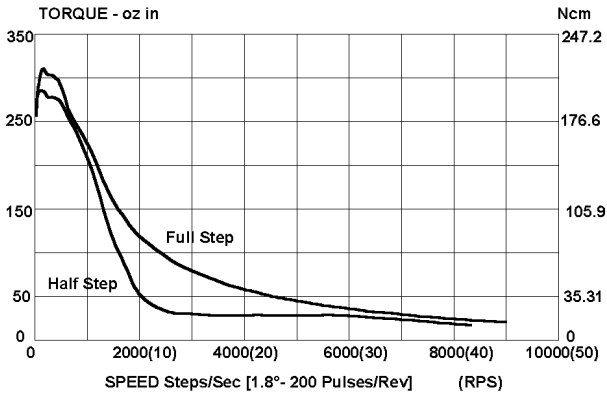

KML063F07, 3.0 Amp

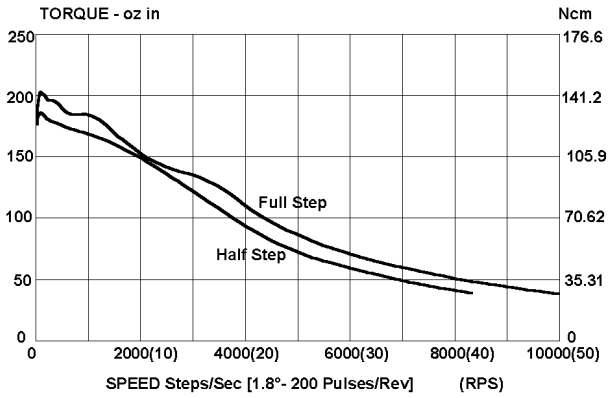

KML063F13, 3.5 Amp

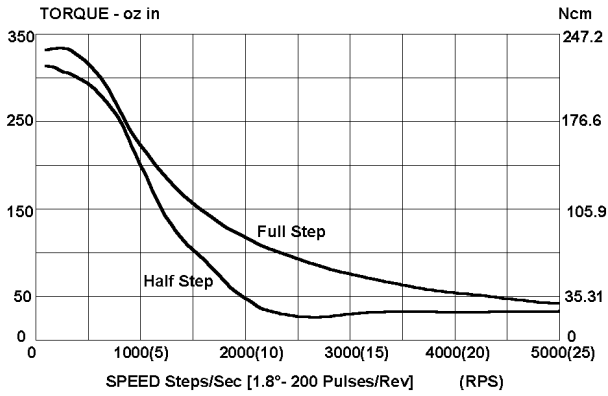

KML091F07, 3.0 Amp

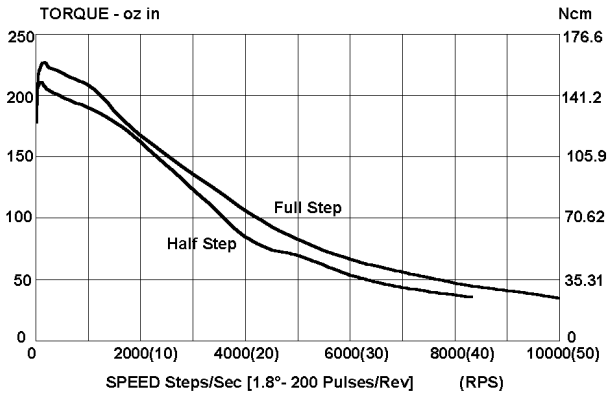

KML091F13, 3.5 Amp

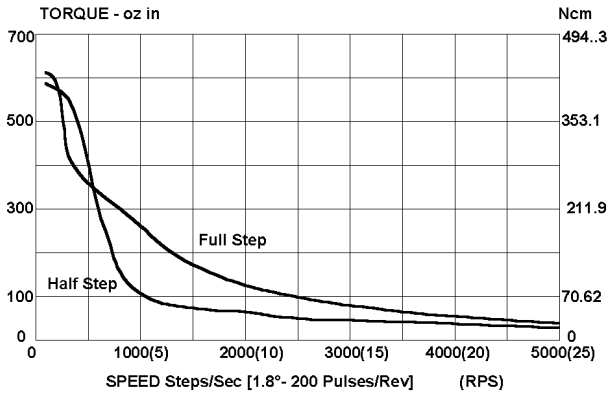

KML092F07, 3.0 Amp

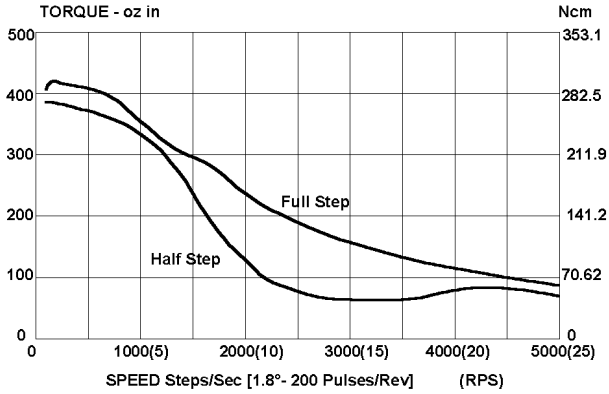

KML092F13, 3.5 Amp

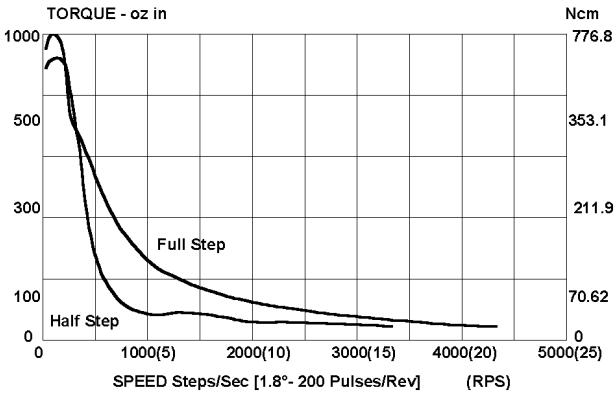

KML093F07, 3.5 Amp

SECTION 6: SYSTEM CHECKING



Motors connected to this drive can develop high torque and large amounts of mechanical energy.

Keep clear of the motor shaft and all parts mechanically linked to the motor shaft.

Turn off all power to the drive before performing work on parts mechanically coupled to the motor.

If installation and operating instructions have been carefully followed, this unit should perform correctly. If the motor fails to step properly, the following checklist will be helpful in locating and correcting the problem.

In General

Check all installation wiring carefully for wiring errors or poor connections.

Ensure that the proper voltage levels are being supplied to the unit.

Be sure that the motor is a correct model for use with this unit.

Specifically

IF MOTOR DIRECTION (CW, CCW) IS REVERSED, Check For:

Reversed connections to the Motor Connector. Reversing the phase A *or* the phase B connections reverses the direction of motor rotation.

IF THE MOTOR MOTION IS ERRATIC, Check For:

Supply voltage out of tolerance.

Proper motion parameters (low speed, acceleration/deceleration, jog speed, home speed and feed rate). Set parameters on controller supplying pulse input to drive.

Filter capacitor missing or too low in value.

IF TORQUE IS LOW, Check For:

All Windings Off active

Correct current setting.

Improper supply voltage.

IF "FAULT" INDICATOR IS NOT LIT, Check For:

Improper motor wiring.

Grounded or shorted wiring to the motor or shorted motor.

Improper motor type or incorrect Current Select switch setting

If a malfunction occurs that cannot be corrected by making the preceding checks, contact Customer Support.

APPENDIX A: TROUBLESHOOTING

A.1 ELECTRICAL INTERFERENCE PROBLEMS

Electrical interference problems are common with today's computer-based controls. Such problems are often difficult to diagnose and cure. If such a problem occurs with your system, it is recommended that the following checks be made to locate the cause of the problem.

1. Check the quality of the AC line voltage using an oscilloscope and a line monitor. If line voltage problems exist, use appropriate line conditioning, such as line filters or isolation transformers.
2. Be certain all recommended wiring practices are followed for location, grounding, wiring and relay suppression (see Section 3.1).
3. Double-check the grounding connections to be sure they are good electrical connections and as short and direct as possible.
4. Try operating the drive with all suspected noise sources switched off. If the drive functions properly, switch the noise sources on again, one at a time, and try to isolate the one(s) causing the interference problems. When a noise source is located, try rerouting wiring, suppressing relays or other measures to eliminate the problem.

A.2 CUSTOMER SUPPORT

Danaher Motion products are available nationwide through an extensive authorized distributor network. These distributors offer literature, technical assistance and a wide range of models off the shelf for fastest possible delivery.

Danaher Motion sales engineers are conveniently located to provide prompt attention to customers' needs. Call the nearest office listed for ordering and application information or for the address of the closest authorized distributor.

In the US and Canada

13500-J South Point Blvd.

Charlotte, NC 28273

Phone: (704) 588-5693

Fax: (704) 588-5695

Email: sales2@danahermotion.com

Website: www.DanaherMotion.com

In Europe

Danaher Motion GmbH & Co. KG

Robert-Bosch-Straße 10

64331 Weiterstadt, Germany

Phone: +49 (0) 6151-8796-10

Fax: +49 (0) 6151-8796-123

Website: www.DanaherMotion.de



Manufactured Under an ISO9001
Compliant Manufacturing System